

Safe-Cell[®] CP-BS Lead Safe[™] Prison Ezy-Grip (Cold only) Basin Set with High Flow Spout

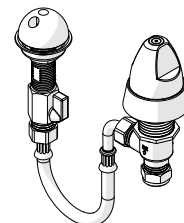

PRODUCT CODE:

- 121.63.23.01

SPECIFICATIONS

- Designed for maximum protection against vandalism.
- Anti-ligature design.
- The basin/sink assembly is made of chrome plated brass.
- Quarter turn ceramic disc.
- Machined cold or hot identification button.
- Available with either Ezy-Grip or Multi-Grip handle (as shown above).
- Lead Safe[™] brass construction*

IMPORTANT: All Safe-Cell[®] prison taps are tested in accordance with AS 3718 and leave our premises in good working order.

*Our Lead Safe[™] product range is compliant with the Lead-Free Requirements of the NCC 2022 Vol. Three, Clause A5G4(2) and NSF/ANSI 372.
**Any flow controller incorporated in the outlet to be tightened to prevent removal by hand. As Per AS3718.

WARNINGS: Special attentions to be paid on notes, photos, images, or drawings of assembly steps marked with the warning symbol.



TECHNICAL DATA

Inlet	1/2" CU / G 1/2"	
Outlet	Basin	
Headwork	Ceramic Disc	
Working Pressure Range (kPa)	Min	50
	Max	500
Working Temperature Range (°C)	Min	5
	Max	65
Nominal Flow Rate (LPM)	4.15	
Finish	Chrome	

NOTE: Galvin Engineering continually strives to improve their products. Specifications may change without prior notice.

TOOLS REQUIRED

- Power drill
- Spanner or adjustable crescent
- Thread tape / sealant

PRE-INSTALLATION

MOUNTING DETAILS

- If the mounting holes do not already exist, mark out and drill the holes in the bench/trough, as shown in rough-in dimensions.

⚠ Note: Supplied flexi hose 225mm long. Maximum distance between outlet and body adjustment is 140mm.

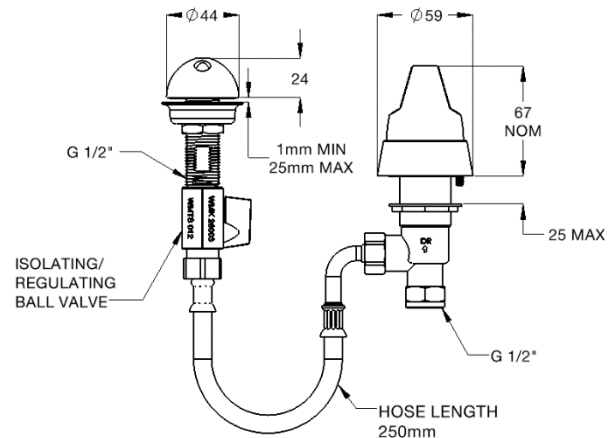
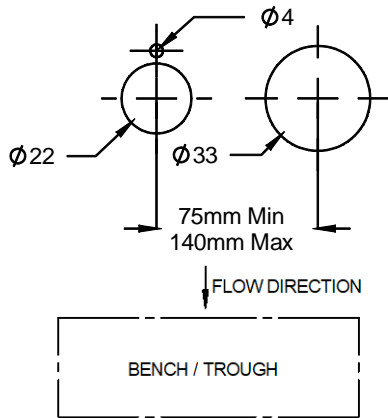

INSTALLATION

INSTALLATION COMPLIANCE: Galvin Engineering products must be installed in accordance with these installation instructions and in accordance with AS/NZS 3500, the PCA and your local regulatory requirements. Water and/or electrical supply conditions must also comply to the applicable national and/or state standards. Failing to comply with these provisions shall void the product warranty and may affect the performance of the product.

IMPORTANT: Whilst our product designs take into account a broad range of installation types and surfaces, it is important that surfaces which fixtures are mounted to are flat and free from defect. This is especially important when installing product ranges that have been designed for correctional and health facilities, where special attention is required to minimise ligature points and areas for concealment of contraband. In addition to ensuring the products are fitted securely and in accordance with the following instructions, consideration shall be given to the use of non-pick mastics such as BASF Sonolastic "Ultra" to ensure a high quality and safe installation.

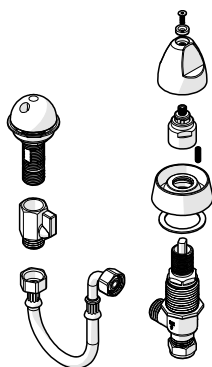

1. Disassembly

- Disassemble components, leaving the bottom nut on the basin body.
- Do not remove the ceramic cartridge

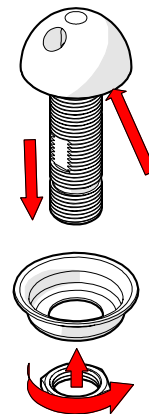

2. Fit basin outlet

- Fit the basin outlet into the bench.
- Ensure the sealing o-ring is placed underneath the outlet and the anti-rotation pin locates properly
- Secure underneath with the supplied cup washer and back nut.

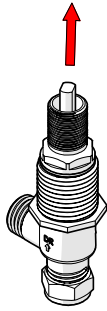

3. Fit basin body

- Insert the basin body assembly up through the pre-cut hole.

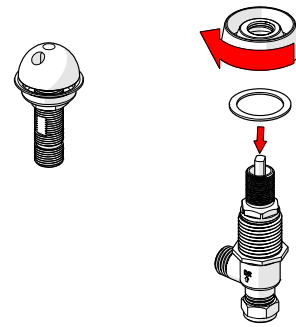

4. Fit dress flange

- Fit dress flange and washer then hand tighten.
- Screw bottom nut up and tighten.
- Tighten nuts holding the breach piece.

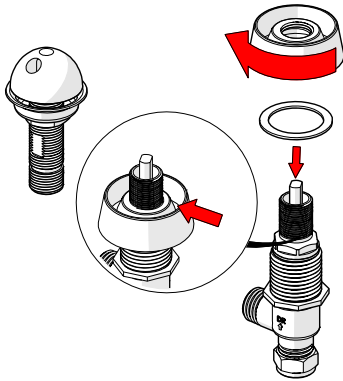

5. Fit dress flange with anti-rotation pin

- If the anti-rotation option is required, fit dress flange onto body and mark the basin/sink, remove the flange and drill 3/16" hole.
- Replace the flange and screw in the grub screw to lock.

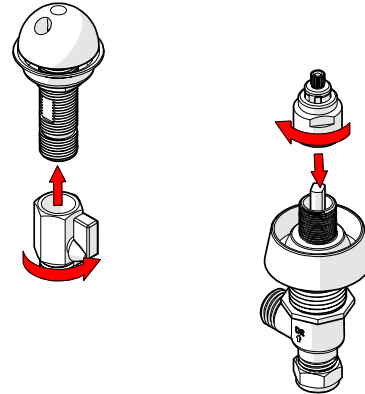

6. Fit lock sleeve & regulating valve

- Fit the lock sleeve and tighten to lock entire unit in position. Take care not to over tighten.
- Assemble isolation valve to the outlet.
- Apply thread sealant or thread tape for sealing. Take care not to over tighten.

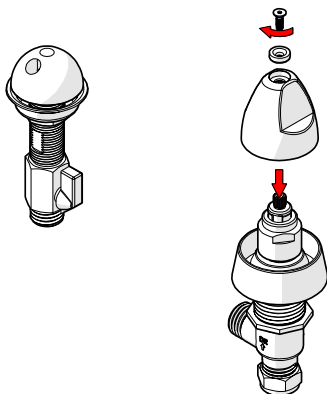

7. Assemble handle

- Fit handle with tamper proof screw; ensure the correct water temperature identification button is in the handle.
- Screw must be tightened before the unit is tested.

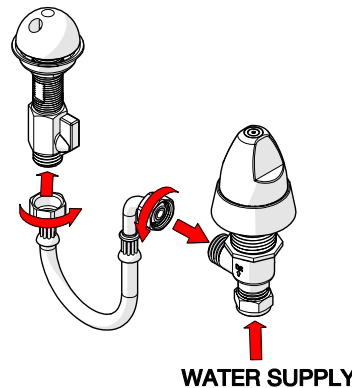

8. Fit flexi hose

- Connect the water supply to the basin body inlet.

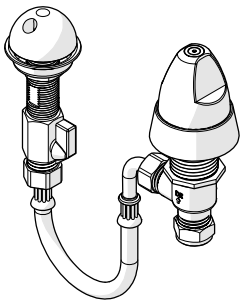

9. Testing

- Turn the handle and ensure that there is flow from the outlet.
- Inspect the tap and check for any leaks.
- Adjust the flow with the isolation valve, so desired flow is achieved.

TROUBLESHOOTING		
PROBLEM	CAUSE	RECTIFICATION
Inconsistent flow	Blocked flow restrictor	Remove isolation valve, remove flow restrictor & clean with water
	Dirt in the top assembly cartridge	Remove cartridge, clean with water and re-grease spindle if required.
Continuous flow	Top assembly cartridge loose or internally obstructed or damaged.	Remove cartridge, clean with water and re-grease spindle if required.
Water is not flowing from tap	Water supply not on	Turn water on
	Blocked flow restrictor	Remove flow regulator from tap and remove debris. Install an inline strainer to stop further blockages.
Taps are dripping water	Ceramic cartridge is worn or damaged	Remove and inspect the cartridge, remove debris and /or replace cartridge if damaged
	Tap seat is damaged	Refurbish tap seat using a reseating tool
Rate of flow inadequate	The flow restrictor may not be satisfactory due to inadequate supply pressure	Remove flow restrictor and replace with a flow restrictor of different capacity to suit (available from Galvin Engineering)

WARRANTY

Galvin Engineering products are covered under our Manufacturer's Warranty. Galvin Engineering products must be installed in accordance with the installation instructions and in accordance with AS 3500 and NCC Volume Three, relevant Australian Standards and local authorities applicable to product being installed. Water and electrical supply conditions must also comply to the applicable national and/or state standards, failing to comply with these provisions may void the product warranty and affect performance of the product.

Please visit www.galvinengineering.com.au to view the full warranty, our Installation Compliance and Maintenance & Cleaning information as well as any other additional information.

Within Australia: 1300 514 074 Outside Australia: P: +61 (0)8 9338 2344

F: +61 (0)8 9338 2340

sales@galvinengineering.com.au

www.galvinengineering.com.au

ABN: 78 008 719 382

PERTH | SYDNEY | MELBOURNE | BRISBANE | ADELAIDE

